

The PCB's are collected from the upstream machine onto a shuttle conveyor and pushed into the designated magazine. Shuttle conveyor moves sideways between upstream machine and magazines.



Standard Features

- Conveyor width adjustment using hand wheel.
- Magazines are manually placed on the platform and clamped in position.
- Safety shutter between conveyor and lifter platform.
- Controlled by PLC.
- Tailor made to the magazine of your choice.
- Regulated pressure on the integrated pusher.
- Pneumatic cylinder used for positioning shuttle conveyor.
- Towerlight display for machine status.
- Threshold signal to protect PCB's in upstream oven.
- Selectable pitch settings.
- CE certified.

Technical specifications

Transfer height:	950 mm ± 25 mm*
Colour:	RAL 9002*
Flow direction:	Left to right*
Fixed rail:	Front*
Machine interface:	SMEMA*
Conveyor concept:	ESD belt
Belt speed:	14 m/min.
PCB edge support:	3 mm
Components clearance:	Top 30 mm, bottom 30 mm (depends on pitch)
Power supply:	230 VAC/50 Hz/1 Ph
Power consumption:	350 VA max.
Air supply:	6 bar
Air consumption:	20 ltr/min max.
PCB unloading time:	± 20 seconds (rear magazine rack)
Pitch control:	1-4, 10 mm pitch
Max. total magazine weight:	50 kg each * or specify

Options

- Pneumatic stopper at inlet to control PCB flow from upstream reflow oven
 - Good- or bad board separation
 - Alarm buzzer
- Other options available on request

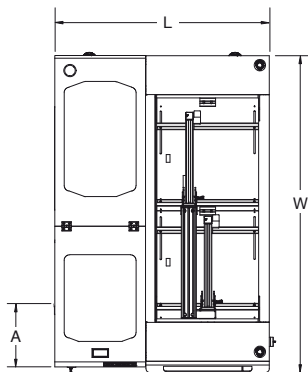

	NTE 0720UL
Machine dimensions (l x w x h)	1250 x 1970 x 1750 mm
Weight	400 kg
PCB length	80 mm - 460 mm
PCB width	70 mm - 460 mm
Magazine dimensions (max.)	535 x 530 x 570 mm
Fixed rail to front dimension (A)	380 mm