

# Dual Lane High Resolution and High Speed Automated Optical Inspection System BF-10D

## Main Features

BF-10D is a dual lane automated optical inspection system with Saki's original alternate scanning system which provides high throughput. Additionally, programming has been greatly improved, and brings enhanced productivity.

## High Throughput

Throughput is now further enhanced by optimized automatic lighting calibration function. Scan time is 30% faster. Operating system is 64 bit with multicore processing, enable faster throughput and at the same time, compatible with the conventional systems. Tact time is about 16 seconds for two M-size (250mm x 330mm) boards and about 12 seconds for two boards of size 150mm x 330mm.

## Programming

Functions useful for inline application have been renewed, including functions such as search pad, search component which helps to enhance the contrast of image affected by application of equivalent parts and oxidation of electrode. By means of the above improvement, changeover time and first pass yield could be improved.

## Compact, Long-life Design

The system equips the camera-driven line scan system and dual lane conveyor system in a compact design. Highly rigidity frame and low-vibration high-speed camera unit makes it possible to provide longer service life with high repeatability.

## Flexible

This dual lane conveyor system is designed to adapt with various placement machines and reflow ovens. It will increase productivity space efficiency and support high speed production.

## High Resolution Imaging System

The system is equipped with a newly developed high-speed multi CCD line scanning camera. Through telecentric lens, it is able to inspect densely mounted 01005(0402) chips. With the further optimization of the LED lighting, a remarkable S/N ratio has been archived through vastly improved color rendering properties.

Full color image

Multi-angle color image

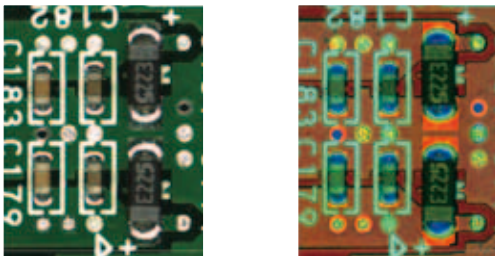

Inspection Program provides appropriate images

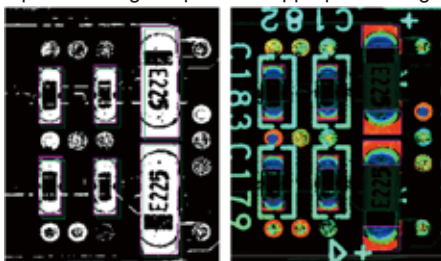

**Dimensions**

■ Front View

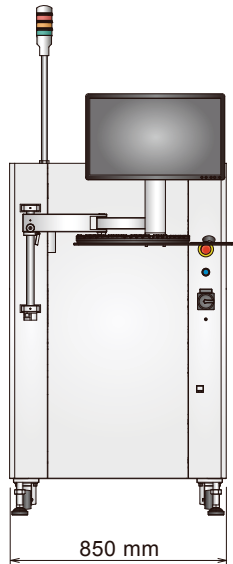

■ Side View

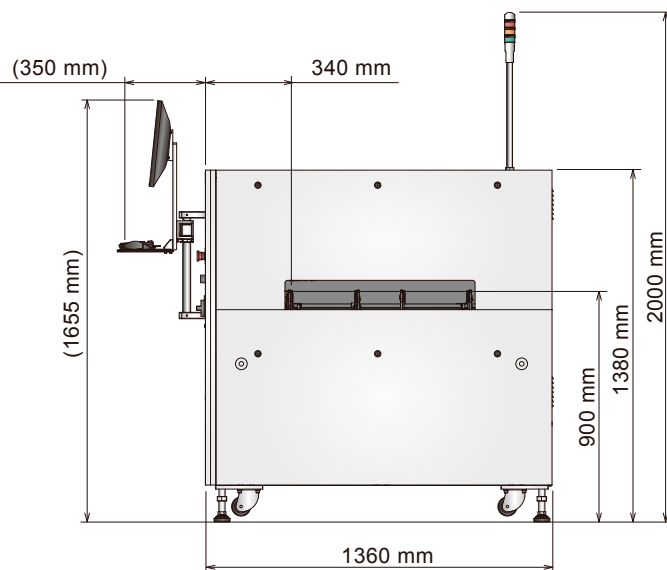

**System Specifications**

Model	BF-10D
Resolution	10μm
Board Size	Single Lane 50×60 - 460×330mm, 2×2.4 - 18×13in. Dual Lane 50×60 - 250×330mm, 2×2.4 - 10×13in.
Board Thickness	0.6 - 3.2mm, 24 - 126mils
Board Warp	+/-2mm, 80mils
PCB Clearance	Top: 40mm, 1.57in. Bottom: 40mm, 1.57in.
Rotated Component Support	Available for 0 - 359° rotation (unit of 1°)
Inspection Categories	Presence/Absence, Misalignment, Tombstone, Reverse, Polarity, Bridge, Foreign material, Absence of solder, Insufficient solder, Lifted lead, Lifted Chip, and Fillet defect. Each defect name can be changed freely by system function.
Tact Time*1 *2	Single Lane Approx. 10sec (250x330mm 1 PCB) Dual Lane Approx. 16sec (250x330mm 2 PCB)
Image Scanning Time*1	Approx. 5.5sec. (250x330mm)
Camera (Image Processing)	Line color CCD camera
Lighting	LED lighting system
Transfer Conveyor Method	Flat belt transfer
Transfer Conveyor Height	900+/-20mm, 36+/-0.8in
Transfer Conveyor Width Adjustment	Automatic
Operating System	Windows 7 English Version
Optional System	BF-Editor / BF-RP1 / BF-Monitor / BF-View
Optional	2D Barcode Recognition, Journal Printer

\*1 If PCB size is smaller than 250x330mm, Image scanning time will be shorter than this values.  
\*2 Including Image Scanning Time.

**Installation Specifications**

Electric Power Requirement	Single Phase ~100 - 120V / 200 - 240V +/-10%, 50/60Hz, 800VA
Air Requirement	0.5MPa, 5L/min (ANR), 73PSI, 0.18CFM
Usage Environment	15°C(59F) - 30°C(86F) / 15 - 80% RH (Non-condensing)
Dimensions*3 W x D x H	850 × 1360 × 1380mm, 33.5 × 53.5 × 54.3in.
Weight	Approx. 450kg, 922.3lbs

\*3 Monitor and keyboard arm is not included.

**saki Saki Corporation**

**Headquarters**

Ogawa Building, 4-14-7, Nakanobu,  
Shinagawa-ku, Tokyo, Japan, 142-0053  
TEL: +81-3-5788-6280 FAX: +81-3-5788-6295  
E-mail: sakicorp@sakicorp.com

**Global Network**

<http://www.sakicorp.com>