



Stereo Dynascopic Microscope for inspection and material rework

- Wide range of magnification x3.5 - x120
- Patented stereo eyepieceless optical technology provides superb resolution and contrast
- Easy hand-to-eye coordination resulting in increased throughput, accuracy and reduced scrap
- Long-life, true colour LED illumination for shadow-free viewing of complex surfaces

Eyepieceless Stereo Dynascopic Microscope



The Lynx stereo microscope utilises Vision Engineering's patented Dynascope technology. Dynascope technology offers the user advanced ergonomics by removing the need for restrictive eyepieces.

Lynx is a unique eyepieceless stereo microscope for intricate tasks requiring high-resolution stereo viewing. The eyepieceless optics of Lynx significantly increase head freedom and eye relief, reducing operator stress and fatigue over long periods of time.

Lynx is used in a wide range of industry applications including general manufacturing, medical devices, electronics, precision engineering, plastics and rubber. The multiple accessories available for the Lynx enable a wide variety of tasks including inspection, manipulation, assembly, dissection, soldering, polishing, finishing and measurement.

Features and Benefits

- Incorporated modern advances in optical design allow your eyes and hands to work together resulting in increased throughput, accuracy and reduced scrap and rework.
- Wide magnification range of x3.5 – x120 provides clear, sharp images with long working distances and large depth of field.

Speed

- Increased head and body freedom for the operator leads to greater productivity, increased throughput, improved quality control and less fatigue.

Versatility

- Modular design allows for quick change over of accessories and options. For example, from rework to high magnification inspection on to image capture.

Ergonomics

- Patented Dynascope technology expands the exit pupil providing head freedom and eye relief for excellent ergonomics, superb hand-to-eye coordination and the ability to wear glasses if required.

Ease of Use

- Lynx offers simple 3-dimensional viewing, with the apparent distance to the viewed object image identical to that of the real object, eliminating re-focussing of the operator's eye; thus reducing the likelihood of fatigue.



Lynx, with swing away boom mount, for flexibility and ease of use.

Stand Options

- Adjustable, swing away, boom mount for mounting directly to user's work surface or with coated platform base for easy transport.

Crank handle option allows convenient vertical adjustment when frequent changes in working distance are required.

- Stable, focusable bench stand with subject holder, substage illumination and floating or measuring stage options.



Lynx bench stand with optional image capture accessory and floating stage

Technical Data

Optical

- Dynascope afocal stereo zoom eyepieceless microscope provides a 26.4° field angle.
- Dynascope patented technology optimises head and body freedom providing 10mm radial head freedom and 70mm axial head freedom.

Zoom Magnification (see table below)

- x7 – x40 multiplied by combinations of objective lenses and multipliers (total zoom magnification range x3.5 – x120).
- Zoom ratio 5.7:1
- Secondary multipliers x1.5 and x2.0
- Reducing objectives to increase working distance and field of view.
- Magnifying objectives to increase total magnification

Illumination

- 14 point LED ring light with intensity control
- Substage illumination (bench stand only) 12V/20W Halogen lamp.
- Option of tilting substage illuminator to enhance contrast

Lynx VS8 PCB Inspection Workstation

- Lynx VS8 is designed for specialist PCB inspection and comes complete with scanning table and a switchable oblique and direct viewer.



Accessories

Oblique and Direct Viewer

- Allows the operator to view a subject from an angle of 34° from vertical, which can be rotated through 360° enabling a better stereo view of 3-dimensional subjects including PCB solder joints, holes, pillars and thread forms.



Oblique and direct viewer

Fixed Angle Viewer

- Allows the user three options; a fixed angle of 25° from vertical, the ability to view vertically or tilting the optical head and using the system standing up.



Fixed angle viewer

Ergowedge

- Allows the view to be adjusted between -5° and -25° from horizontal.



Ergowedge

Image Capture and Archive

- Enhance your capabilities with a range of digital and USB camera options.
- Modular multimedia solutions for image archiving, acquisition, processing, analysis and documentation.



Image capture and archive

Step Magnification Multiplier

- Allows the stereo zoom range to be increased by a factor of x1.5 or x2 without any loss in working distance.



Step magnification multiplier

Measuring/Comparison Graticule

- Allows the user the ability to measure and compare against a scale. Standard range is available as a crossline or graduated scale. Custom graticules can be manufactured to specific designs.

Objective Lens	Zoom Range			Working Distance	Field of View at Max. Zoom			Field of View at Min. Zoom		
		with x1.5 multiplier	with x2.0 multiplier			with x1.5 multiplier	with x2.0 multiplier		with x1.5 multiplier	with x2.0 multiplier
x0.5	x3.5 – x20	x5.3 – x30	x7.0 – x40	177mm	6.7mm	4.3mm	3.3mm	38.0mm	25.3mm	19.0mm
x0.7	x4.9 – x28	x7.4 – x42	x9.8 – x56	130mm	4.8mm	3.2mm	2.4mm	27.0mm	18.0mm	13.5mm
x1.0	x7.0 – x40	x10.5 – x60	x14 – x80	85mm	3.5mm	2.3mm	1.7mm	18.7mm	12.5mm	9.4mm
x1.5	x10.5 – x60	x15.8 – x90	x21 – x120	47mm	2.3mm	1.5mm	1.2mm	12.9mm	8.6mm	6.5mm

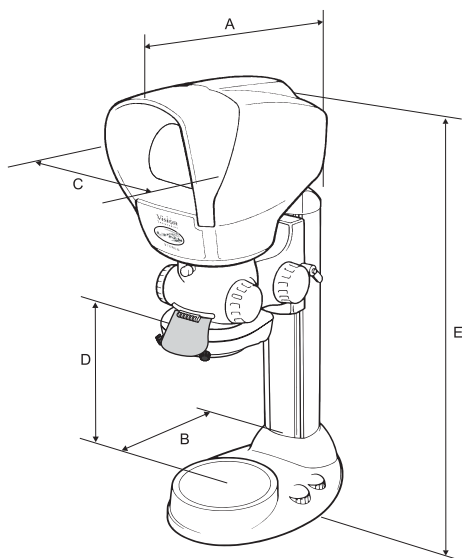

Lynx Bench Stand

Bench Stand:

- A = 280mm
- B = 150mm
- C = 200mm
- D = 150mm max, less working distance
- E = 760mm

Unpacked weight: 18.0kg
Packed weight: 22.0kg

Boom Mount:

- F = 400mm maximum
- G = 310mm max, less working distance
- H = 435mm

Unpacked weight: 18.0kg
Packed weight: 22.0kg

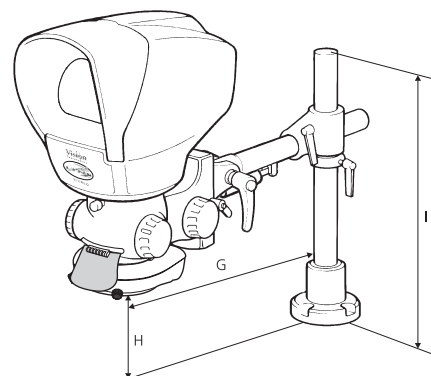

Lynx Boom Mount

For more information...

Vision Engineering has a network of offices and technical distributors around the world. For more information, please contact your Vision Engineering branch, local authorised distributor, or visit our website.

Vision Engineering Ltd.
(Manufacturing)
Send Road, Send, Woking,
Surrey, GU23 7ER, England
Tel: +44 (0) 1483 248300
Fax: +44 (0) 1483 223297
Email: generalinfo@visioneng.com

Vision Engineering Inc.
(Manufacturing & Commercial)
570 Danbury Road, New Milford,
CT 06776 USA
Tel: +1 (860) 355 3776
Fax: +1 (860) 355 0712
Email: info@visioneng.com

Vision Engineering Ltd.
(Central Europe)
Anton-Pendele-Str. 3,
82275 Emmering, Germany
Tel: +49 (0) 8141 40167-0
Fax: +49 (0) 8141 40167-55
Email: info@visioneng.de

Vision Engineering Ltd.
(France)
ZAC de la Tremblaie, Av. de la Tremblaie
91220 Le Plessis Paté, France
Tél: +33 (0) 160 76 60 00
Fax: +33 (0) 160 76 60 01
Email: info@visioneng.fr

Vision Engineering Ltd.
(Commercial)
Monument House, Monument Way West,
Woking, Surrey, GU21 5EN, England
Tel: +44 (0) 1483 248300
Fax: +44 (0) 1483 248301
Email: generalinfo@visioneng.com

Vision Engineering Inc.
(Commercial West Coast)
745 West Taft Avenue, Orange,
CA 92865 USA
Tel: +1 (714) 974 6966
Fax: +1 (714) 974 7266
Email: info@visioneng.com

Nippon Vision Engineering
(Japan)
272-2 Saedo-cho, Tsuduki-ku,
Yokohama-shi, 224-0054, Japan
Tel: +81 (0) 45 935 1117
Fax: +81 (0) 45 935 1177
Email: info@visioneng.jp

Vision Engineering Ltd.
(Italy)
Via Cesare Cantù, 9
20092 Cinisello Balsamo MI, Italy
Tel: +39 02 6129 3518
Fax: +39 02 6129 3526
Email: info@visioneng.it

Vision Engineering Ltd
(China)
11J, International Ocean Building,
720 Pudong Avenue, Shanghai,
200120, P.R. China
Tel: +86 (0) 21 5036 7556
Fax: +86 (0) 21 5036 7559
Email: info@visioneng.com.cn

Vision Engineering
(India)
Email: info@visioneng.co.in

Vision Engineering
(S.E. Asia)
Email: info@visioneng.asia

Visit our multi-lingual website:
www.visioneng.com

Distributor:

AMTECH spol. s r.o.
Banskobystrická 141, 621 00 Brno
Kancelář : Palackého tř. 153b, 621 00 Brno
tel.: +420 541 225 215 fax: +420 541 228 285
email: amtech@amtech.cz
www.amtech.cz

