

6-Axis F/T sensor

HEX-H

Benefits:

- Multi axis force measurement
- High resolution
- Dust and water proof (IP65)
- High overload range
- Mechanical shock resistant
- Cost efficient solution
- Easy integration
- Mechanical overload protection

Description:

OptoForce 6 axis F/T sensors provide 6 degrees of freedom force and torque measurement. Our sensors are designed to fit most of the currently used industrial robot arms. Integration with the various available interfaces is simple. Common applications are **force control** devices, **teach in activities**, and **crash detection**, but the sensors can be used next to **end effectors** in case of **grinding**, **polishing** or **deburring** tools. High durability and an unlimited number of custom opportunities resemble all of our sensor types.

We offer these sensors mostly for **system integrator** companies, **robot arm manufacturers**.

	Nominal Capacity	Deformation (Deflection)
F _{xy}	± 200 N	± 0.6 mm
F _z	± 200 N	± 0.25 mm
T _{xy}	± 20 Nm	(± 2 °)
T _z	± 13 Nm	(± 3.5 °)



Sensor Dimensions

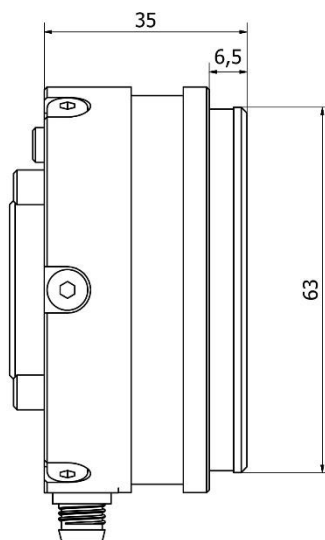
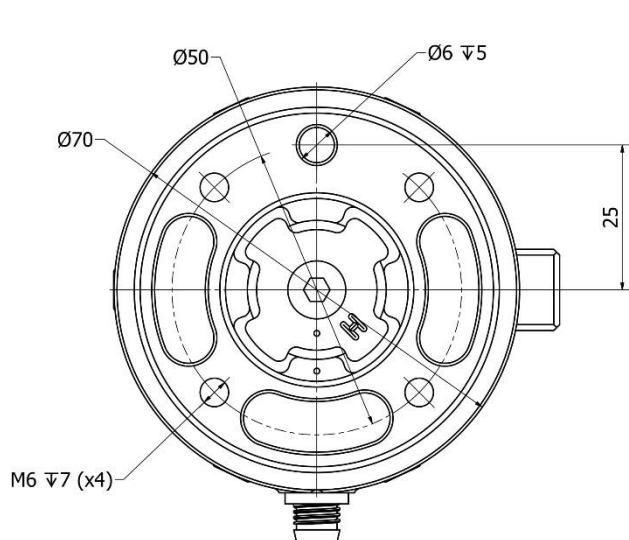

Connector pinout

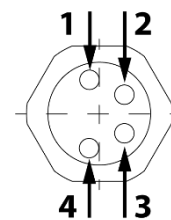

- 1 : V+
- 2 : CAN High
- 3 : V-
- 4 : CAN Low

SPECIFICATIONS

Sensor Type	6-Axis Force/Torque Sensor			
Dimensions	Height x diameter		35 x 70 mm	
Weight	(With built-in adapter plates)		260g	
	Fxy	Fz	Txy	Tz
Nominal Capacity (N.C)	200 N	200 N	20 Nm	13 Nm
Single axis overload	500 %	500 %	300 %	300 %
Signal noise ¹ (typical)	0.1 N	0.2 N	0.006 Nm	0.002 Nm
Noise-free resolution (typical)	0.5 N	1 N	0.035 Nm	0.008 Nm
Single axis deformation at N.C (typical)	±0.6 mm	± 0.25 mm	± 2 °	± 3.5 °
Full scale nonlinearity	< 2%			
Hysteresis (measured on Fz axis , typical)	< 2 %			
Crosstalk (typical)	< 5 %			
Working temperature range	All axes		0 C° - +55 C°	
Power requirement	DC input range 7-24V		0.8 W	
Sensor mounting screws	5 x M4 x 8 mm 1 x M4 x 12 mm		DIN7984	
Tool mounting screws	4 x M6 x 8 mm		DIN7984	

¹ : Signal noise is defined as the standard deviation (1 σ) of a typical one second no-load signal.

INTERFACE TYPES

USB	CAN	Ethernet - TCP/UDP	EtherCAT
Maximum sampling frequency 500 Hz			
Supported systems Windows; Linux; ROS; UR			

Adapter A

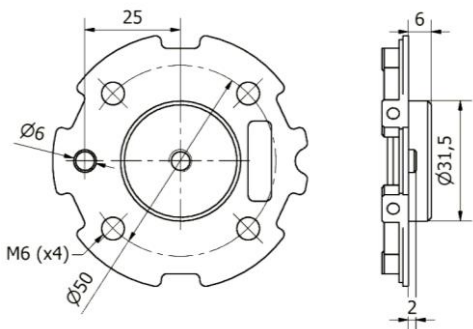

Adapter B

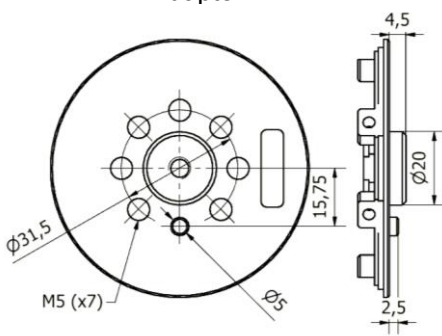

Adapter C

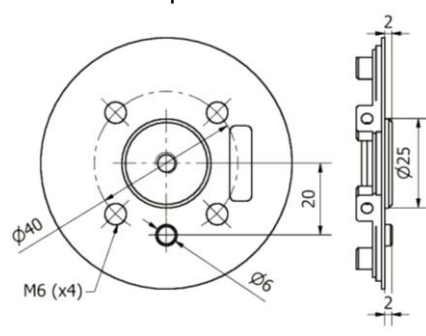

Adapter A	Adapter B	Adapter C
Universal Robots UR3	ABB IRB 120	ABB IRB 1410
Universal Robots UR5	ABB IRB 1200	ABB IRB 2400L
Universal Robots UR10	KUKA KR3 Agilus	KUKA KR6
KUKA KR20	KUKA KR Agilus sixx	KUKA KR16
	KUKA KR Agilus five	KUKA KR16 L6
	KR Cybertech nano	KUKA KR16 S



COMPLEX LOADING

During single-axis loading the sensor could only be operated up to its nominal capacity. Above the nominal capacity the reading is inaccurate and invalid.

During complex loading (*when more than one axis is loaded*) the nominal capacities can be reduced. The following diagrams show the affected complex loading scenarios.

Please note that the sensor **could not be operated** outside of the Normal Operating Area.

